

PLC-RSC- 24DC/1IC/ACT

Order No.: 2967604



<http://eshop.phoenixcontact.de/phoenix/treeViewClick.do?UID=2967604>

PLC relay, consisting of base terminal block PLC-BSC.../1 IC/ACT with screw connection and pluggable miniature relay, for high inrush currents, for assembly on mounting rail NS 35/7.5, 1 N/O contact, input voltage 24 V DC, max. inrush current up to 130 A



Commercial data

EAN	4017918169794
Pack	10 Pcs.
Customs tariff	85364900
Weight/Piece	0.06838 KG
Catalog page information	Page 74 (IF-2007)

Product notes

WEEE/RoHS-compliant since:
04/19/2006



<http://www.download.phoenixcontact.com>
Please note that the data given here has been taken from the online catalog. For comprehensive information and data, please refer to the user documentation. The General Terms and Conditions of Use apply to Internet downloads.

Technical data

Coil side

Nominal input voltage U_N	24 V DC
Nominal input current at U_N	18 mA
Typical response time	8 ms

Typical release time	10 ms
Operating voltage display	Yellow LED
Name of protection	Polarity protection
Protective circuit/component	Polarity protection diode

Contact side

Contact type	Single contact, 1 N/O contact
Contact material	AgSnO
Maximum switching voltage	250 V AC/DC (The separating plate PLC-ATP should be installed for voltages larger than 250 V (L1, L2, L3) between identical terminal blocks in adjacent modules. Potential bridging is then carried out with FBST 8-PLC... or ...FBST 500...)
Minimum switching voltage	12 V AC/DC
Maximum inrush current	80 A (for 20 ms) 130 A (peak, at capacitive load, 230 V AC, 24 µF)
Min. switching current	100 mA
Limiting continuous current	6 A
Interrupting rating (ohmic load) max.	10 A (the value is permissible if both connections 13, both connections 14 and both connections BB are bridged) 144 W (for 24 V DC) 240 W (for 24 V DC. The value is permissible if both connections 13, both connections 14 and both connections BB are bridged.) 58 W (for 48 V DC) 48 W (for 60 V DC) 50 W (for 110 V DC) 80 W (for 220 V DC) 1500 VA (for 250 V AC) 2500 VA (for 250 V AC. The value is permissible if both connections 13, both connections 14 and both connections BB are bridged.)

General data

Length	80 mm
Height	94 mm
Width	14 mm
Test voltage relay winding/relay contact	4 kV AC (50 Hz, 1 min)
Ambient temperature (operation)	-25 °C ... 60 °C
Ambient temperature (storage/transport)	-40 °C ... 85 °C
Operating mode	100% operating factor

Service life mechanical	3 x 10 ⁷ cycles
Inflammability class in acc. with UL 94 (housing)	V0
Standard designation	Standards/regulations
Standards/regulations	IEC 60664
	IEC 60664 A
	DIN VDE 0110
	DIN EN 50178/DIN VDE 0160 (in relevant parts)
	IEC 60255/DIN VDE 0435 (in relevant parts)
	DIN EN 50178/VDE 0160
Pollution degree	3
Surge voltage category	III
Mounting position	Any
Assembly instructions	In rows with zero spacing

Connection data

Type of connection	Screw connection
Conductor cross section solid min.	0.14 mm ²
Conductor cross section solid max.	2.5 mm ²
Conductor cross section stranded min.	0.14 mm ²
Conductor cross section stranded max.	2.5 mm ²
Conductor cross section AWG/kcmil min.	26
Conductor cross section AWG/kcmil max	14
Stripping length	8 mm
Screw thread	M 3

Certificates / Approvals

Approval logo



requested approbations

Certification	CUL, CUL Listed, GL, GOST, UL, UL Listed
---------------	--

Accessories		
Item	Designation	Description
Assembly		
0801762	NS 35/ 7,5 CU UNPERF 2000MM	DIN rail, material: Copper, unperforated, height 7.5 mm, width 35 mm, length: 2 m
0801733	NS 35/ 7,5 PERF 2000MM	DIN rail, material: Steel, perforated, height 7.5 mm, width 35 mm, length: 2 m
0801681	NS 35/ 7,5 UNPERF 2000MM	DIN rail, material: Steel, unperforated, height 7.5 mm, width 35 mm, length: 2 m
0801377	NS 35/ 7,5 V2A UNPERF 2000MM	DIN rail, material: High-grade steel V2A, unperforated, height 5.5 mm, width 15 mm, length: 2 m
1201756	NS 35/15 AL UNPERF 2000MM	DIN rail, deep-drawn, high profile, unperforated, 1.5 mm thick, material: Aluminum, height 15 mm, width 35 mm, length 2 m
1201895	NS 35/15 CU UNPERF 2000MM	DIN rail, material: Copper, unperforated, 1.5 mm thick, height 15 mm, width 35 mm, length: 2 m
1201730	NS 35/15 PERF 2000MM	DIN rail, material: Steel, perforated, height 15 mm, width 35 mm, length: 2 m
1201714	NS 35/15 UNPERF 2000MM	DIN rail, material: Steel, unperforated, height 15 mm, width 35 mm, length: 2 m
1201798	NS 35/15-2,3 UNPERF 2000MM	DIN rail, material: Steel, unperforated, 2.3 mm thick, height 15 mm, width 35 mm, length: 2 m
2966841	PLC-ATP BK	Separating plate, 2 mm thick, required at the start and end of a PLC terminal strip. Furthermore, it is used for: visual separation of groups, safe isolation of different voltages of neighboring PLC relays in acc. with DIN VDE 0106-101, isolation
Bridges		
2966812	FBST 6-PLC BU	Plug-in bridge, 2-pos., 6 mm long, insulated, for potential distribution with PLC, color of the insulation material: blue
2966825	FBST 6-PLC GY	Plug-in bridge, 2-pos., 6 mm long, insulated, for potential distribution with PLC, color of the insulation material: gray
2966236	FBST 6-PLC RD	Plug-in bridge, 2-pos., 6 mm long, insulated, for potential distribution with PLC, color of the insulation material: red
2967688	FBST 8-PLC GY	Plug-in bridge, 2-pos., 8 mm long, insulated, for potential distribution with PLC, with separating plate, color of the insulation material: gray
2967691	FBST 14-PLC BK	Plug-in bridge, 2-pos., 14 mm long, insulated, to increase efficiency with PLC...IC and PLC..HC, color of the insulation material: black
2966692	FBST 500-PLC BU	Continuous plug-in bridge, 500 mm long, insulated, can be cut to length, for potential distribution with PLC..., color of the insulating material: blue

2966838	FBST 500-PLC GY	Continuous plug-in bridge, 500 mm long, insulated, can be cut to length, for potential distribution with PLC..., color of the insulating material: gray
2966786	FBST 500-PLC RD	Continuous plug-in bridge, 500 mm long, insulated, can be cut to length, for potential distribution with PLC..., color of the insulating material: red

Marking

1053001	ZB 10:UNBEDRUCKT	Zack strip, unprinted: 10-section, for individual labeling with M-PEN, ZB-T or CMS system, sufficient for 100 terminal blocks, for a terminal width of 10.2 mm, color: White
1053014	ZB10,LGS:FORTL.ZAHLEN	Zack strip, 10-section, printed horizontally: with the numbers, 1-10, 11-20 etc. up to 991-1000, color: white
5060883	ZB10/WH-100:UNBEDRUCKT	Zack strip, unprinted: 10-section, for individual labeling with M-PEN, ZB-T or CMS system, large batch, sufficient for labeling 1000 terminal blocks, for a terminal width of 10.2 mm, color: White

Drawings

Diagram

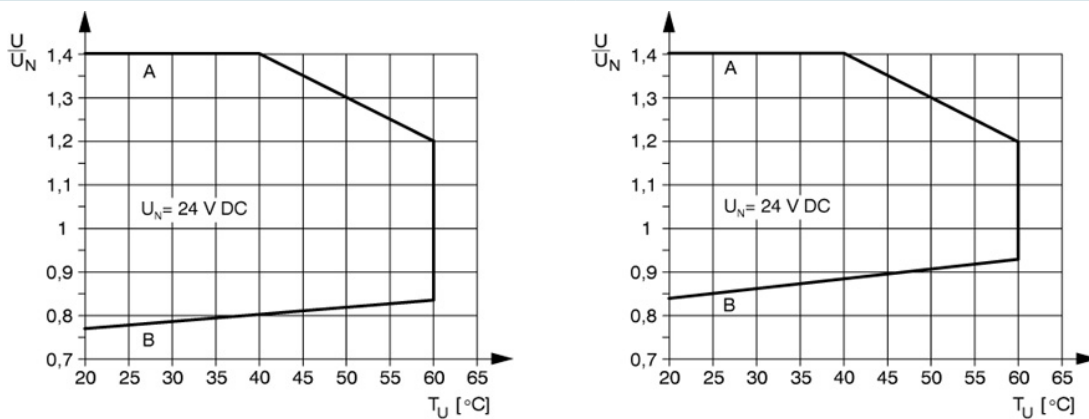

Circuit diagram

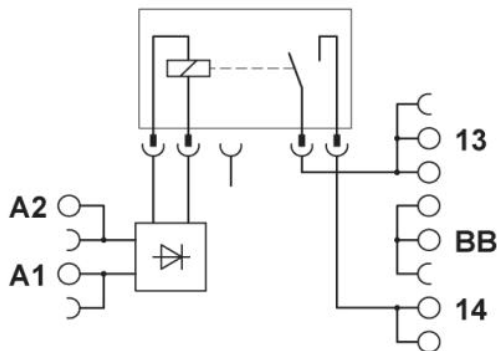

Address

PHOENIX CONTACT Inc., USA
586 Fulling Mill Road
Middletown, PA 17057, USA
Phone (800) 888-7388
Fax (717) 944-1625
<http://www.phoenixcon.com>



© 2008 Phoenix Contact
Technical modifications reserved;